

D16/M
CONTROL
SEQUENCE

INSTRUCTION
DETAILS

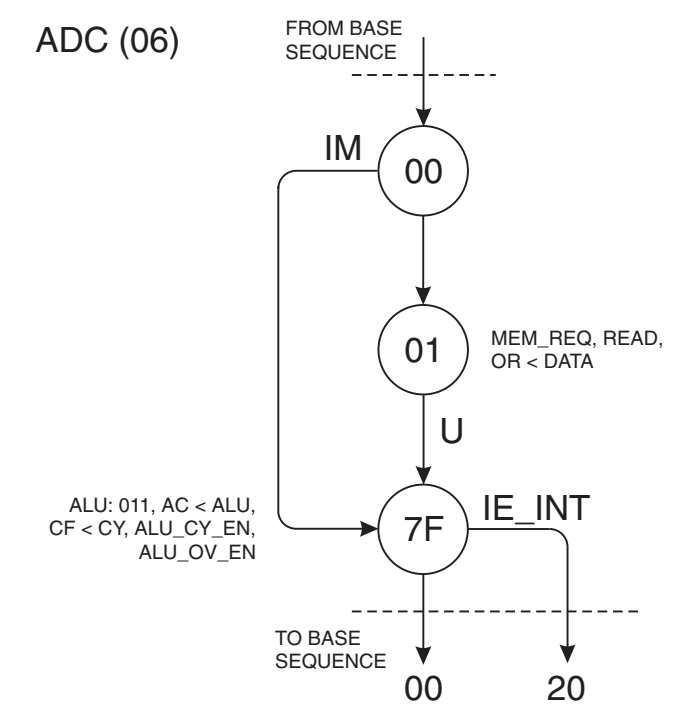

SUB (07)

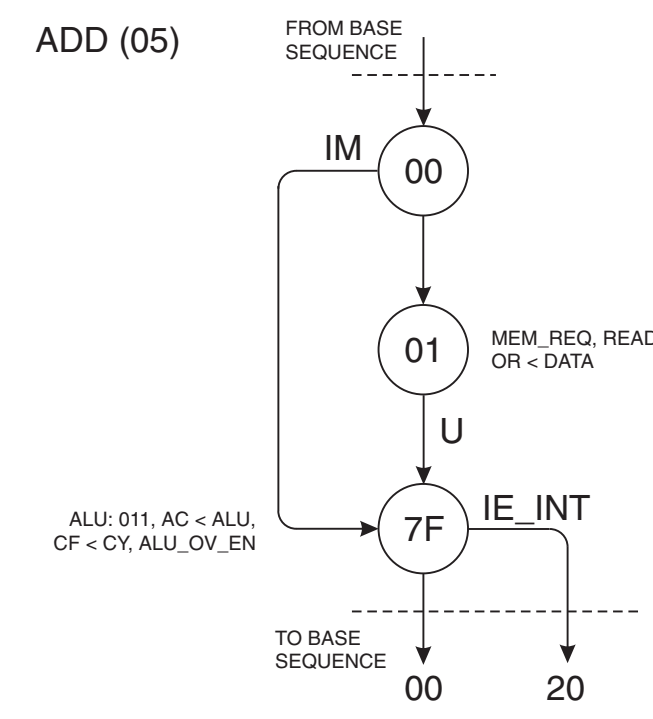
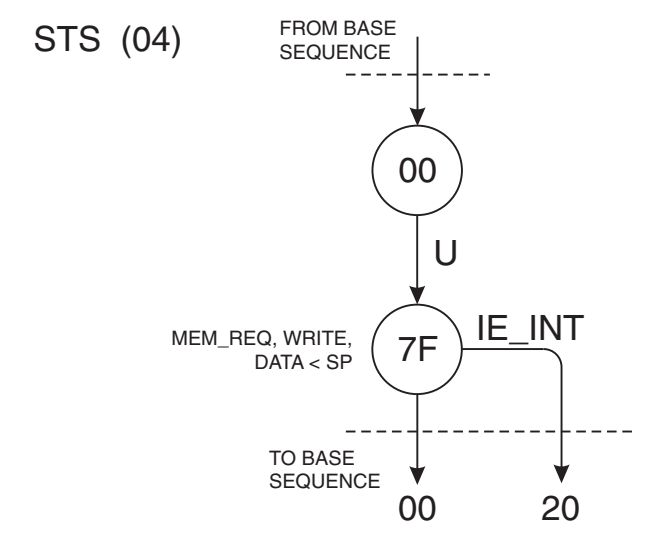
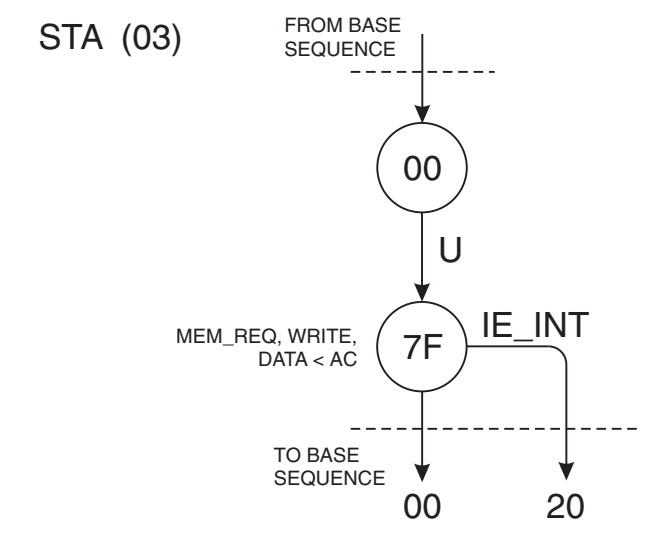
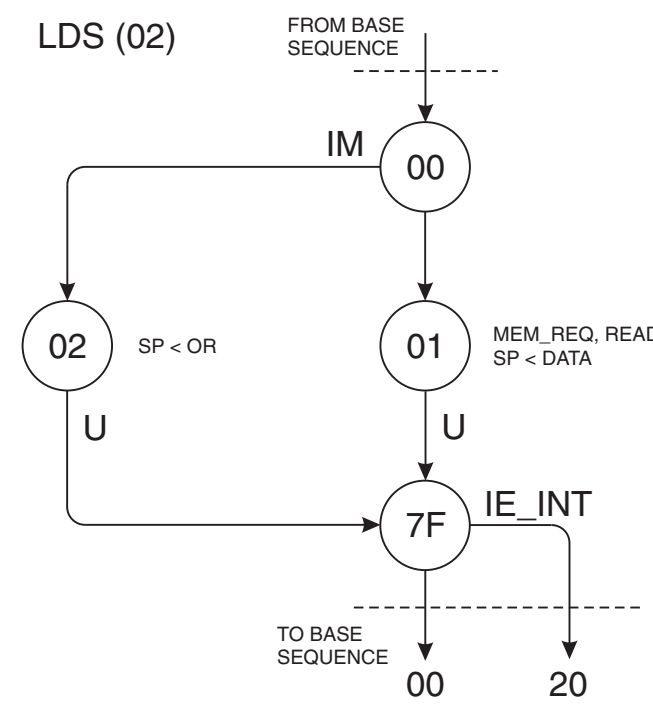
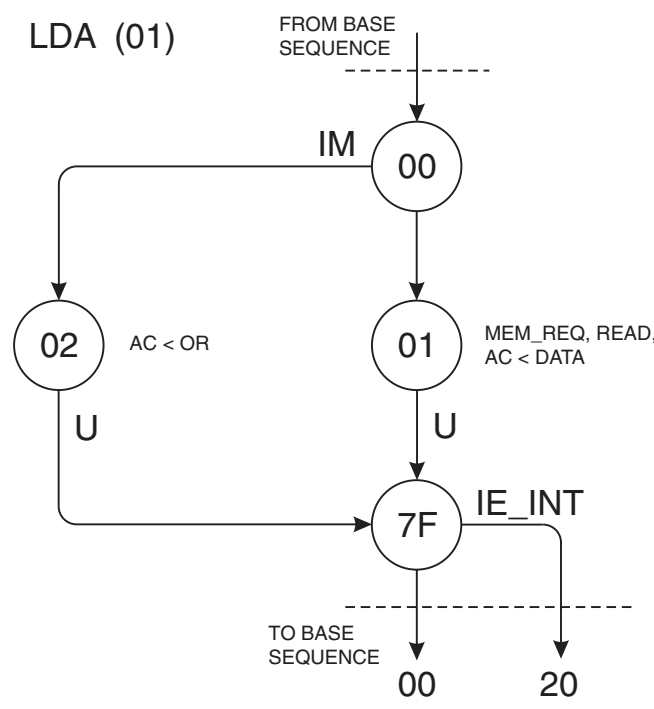
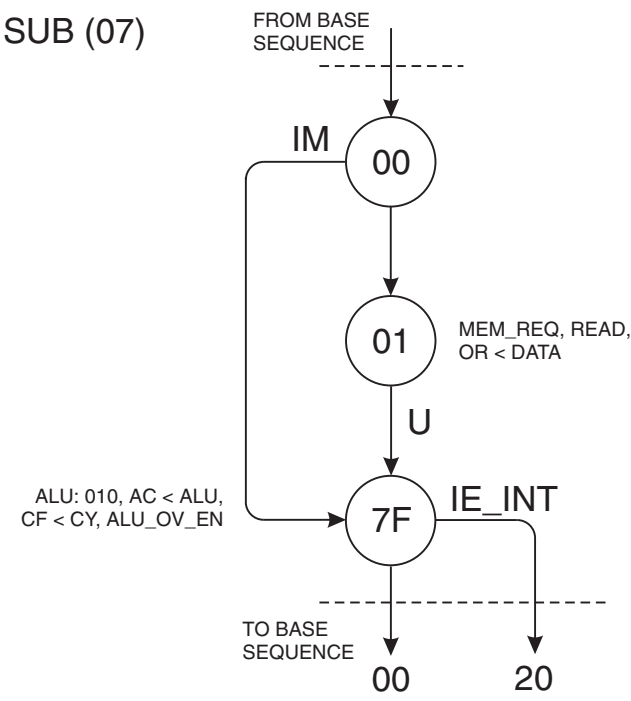

SBC (08)

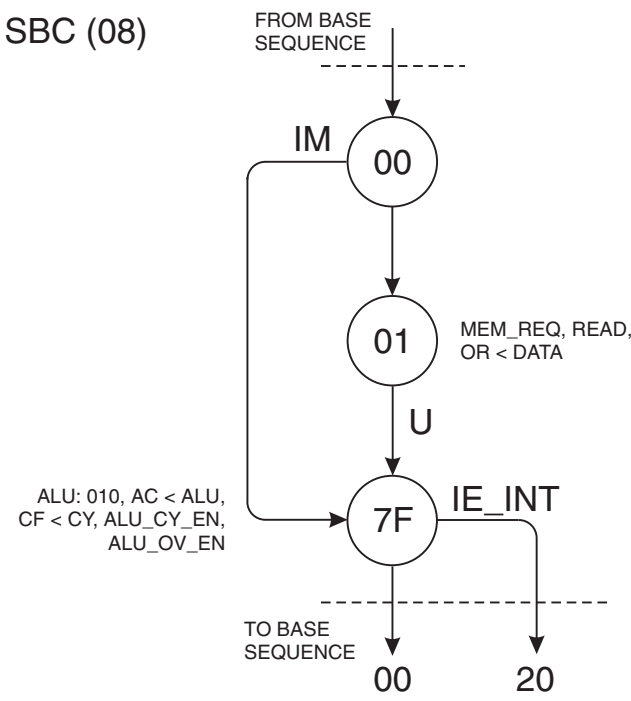

AND (09)

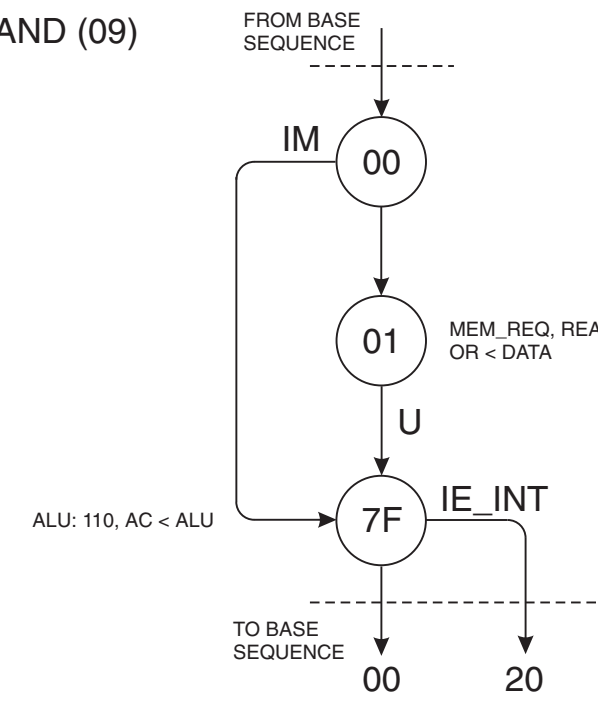

ORA (0A)

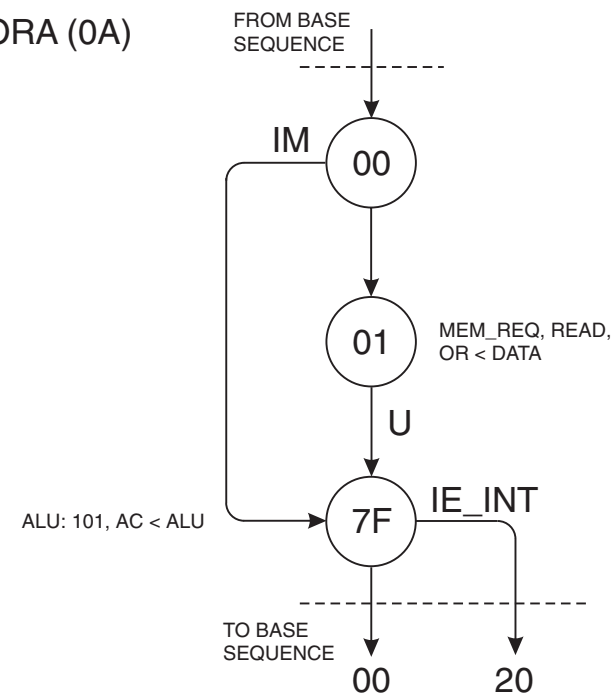

XOR (0B)

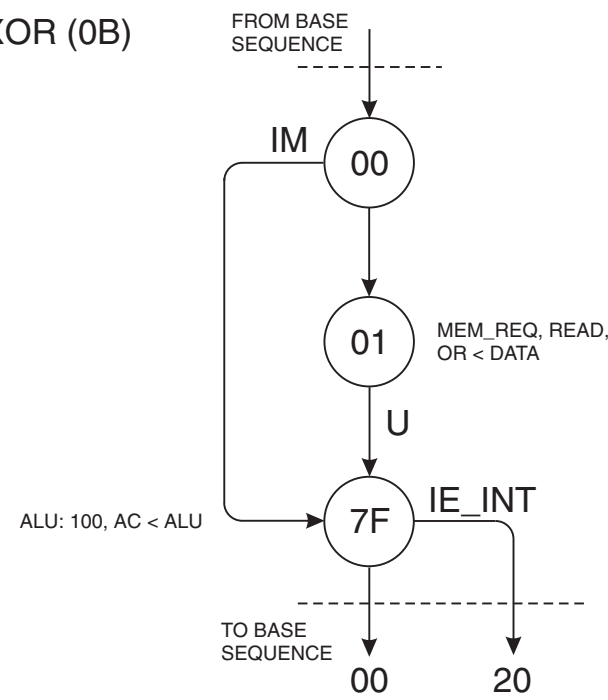

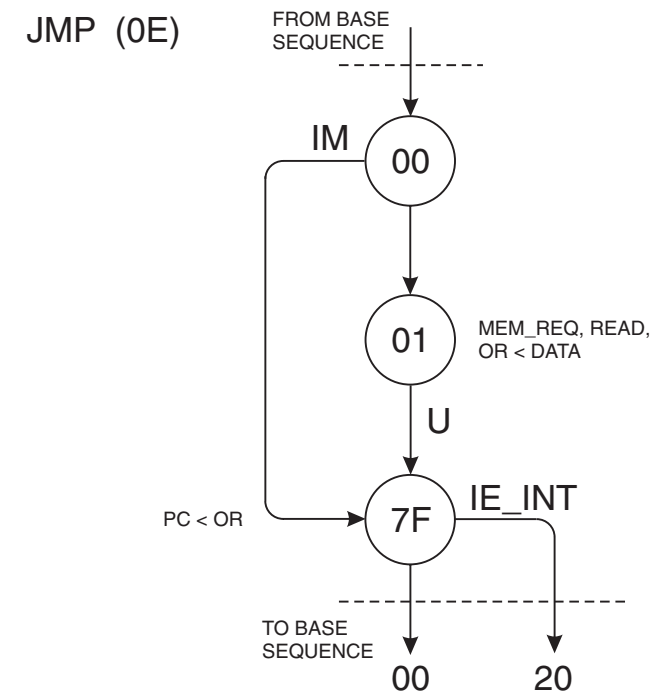
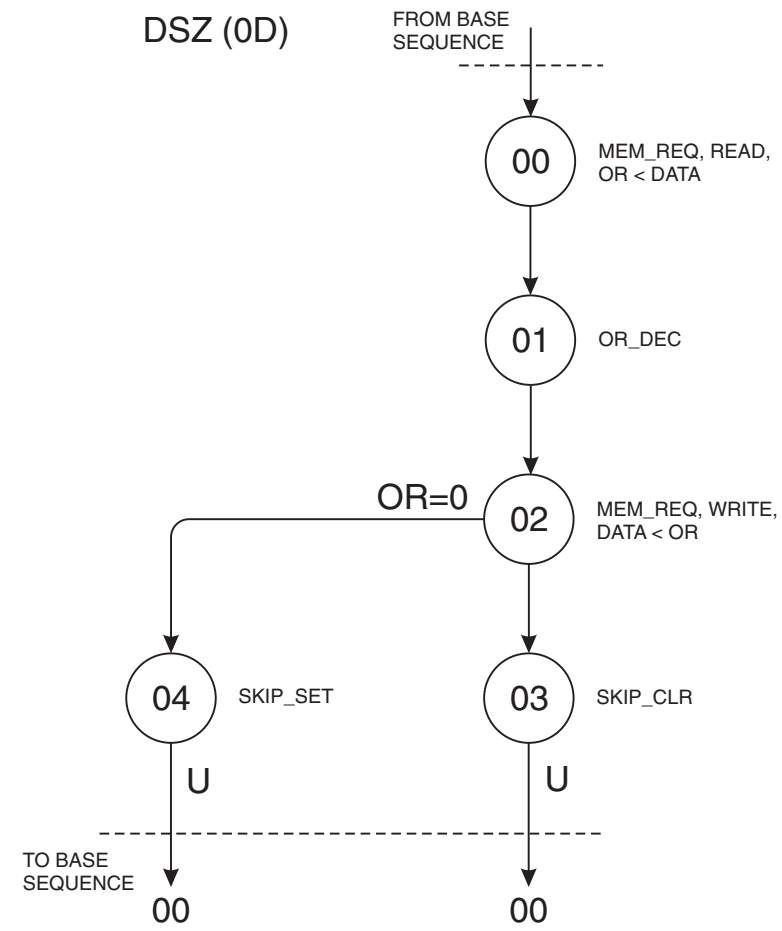
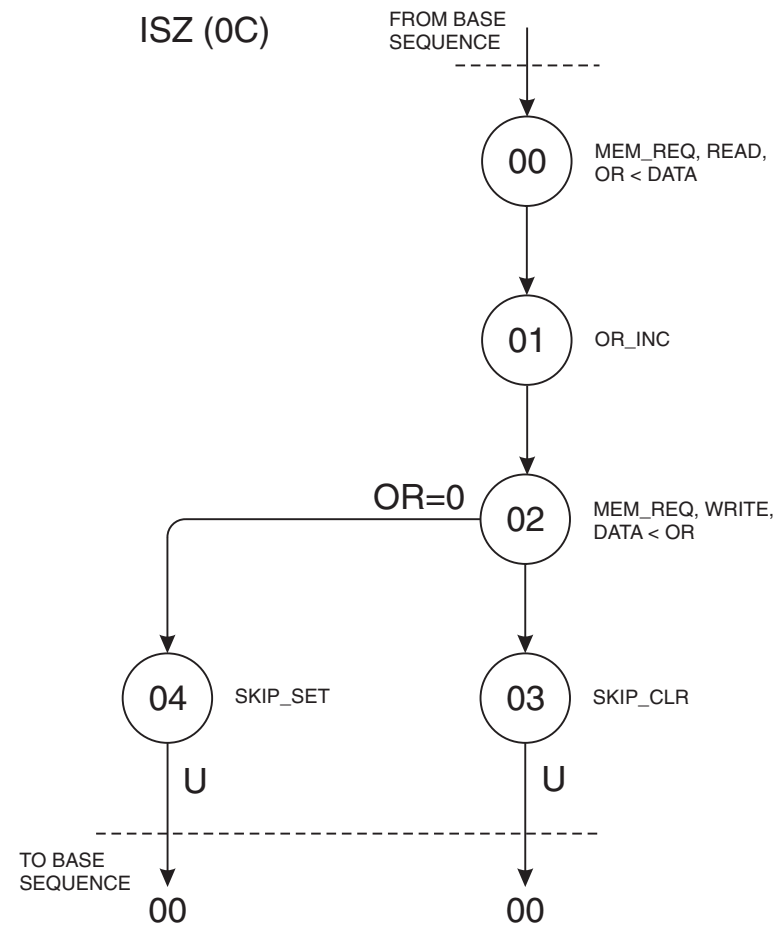

JOZ (0F)

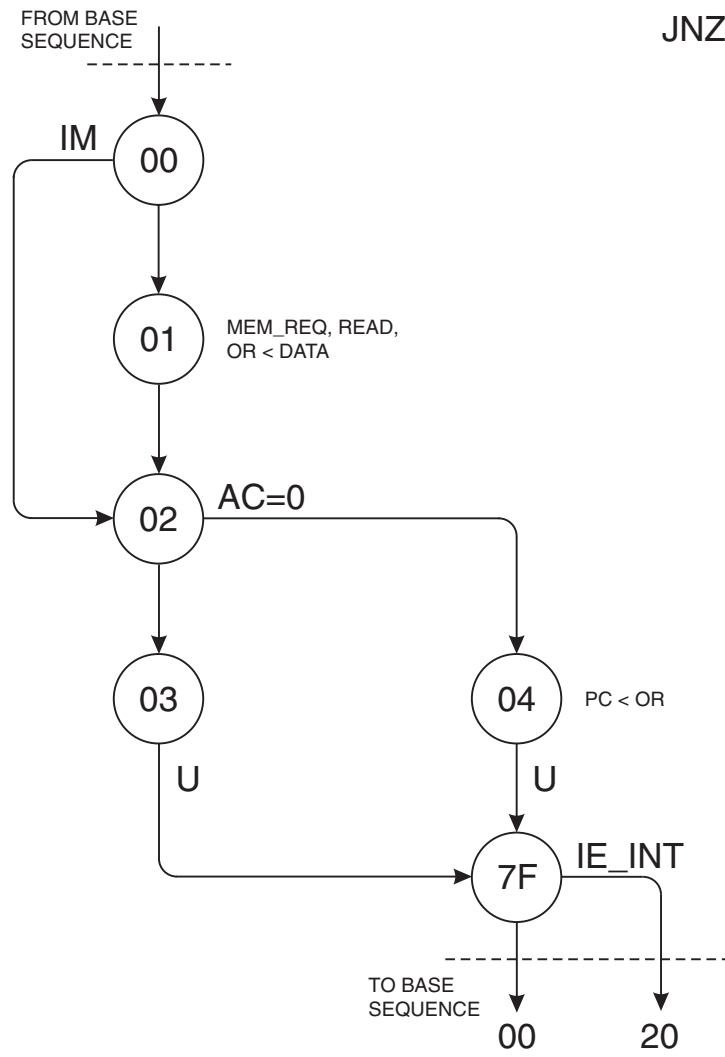

JNZ (10)

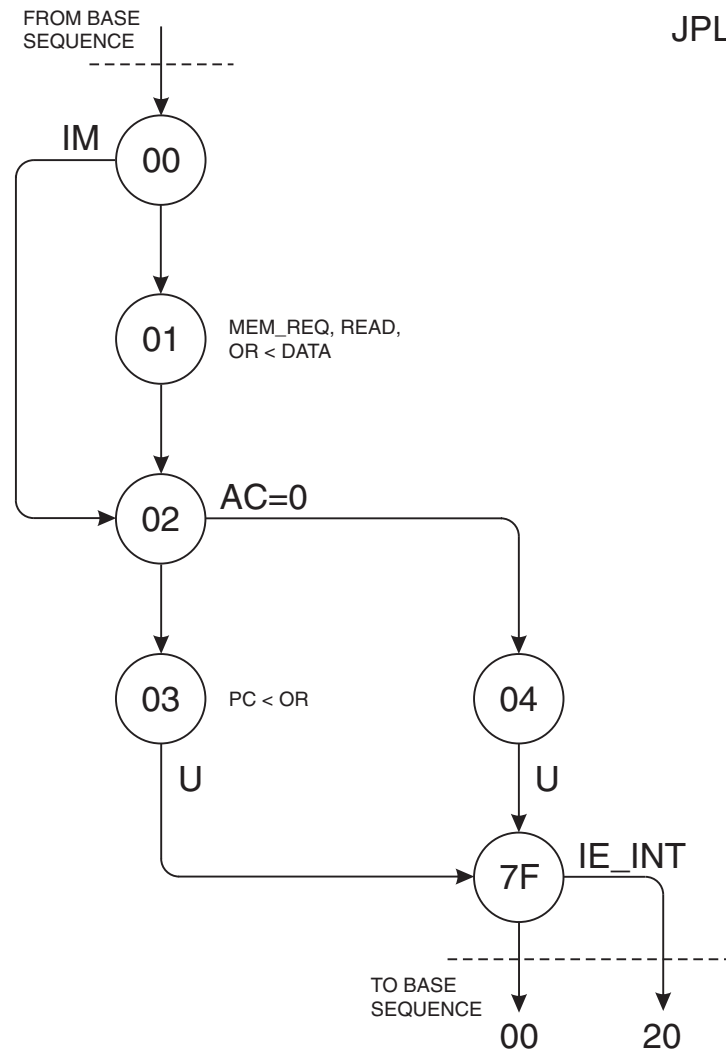

JPL (11)

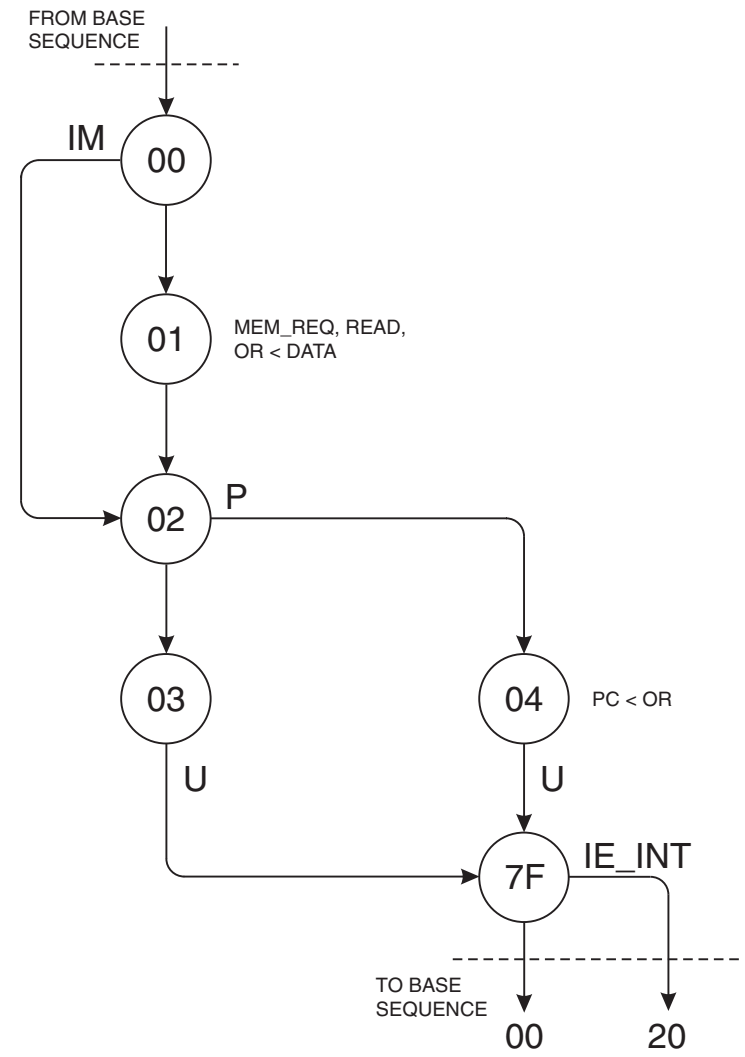

JMI (12)

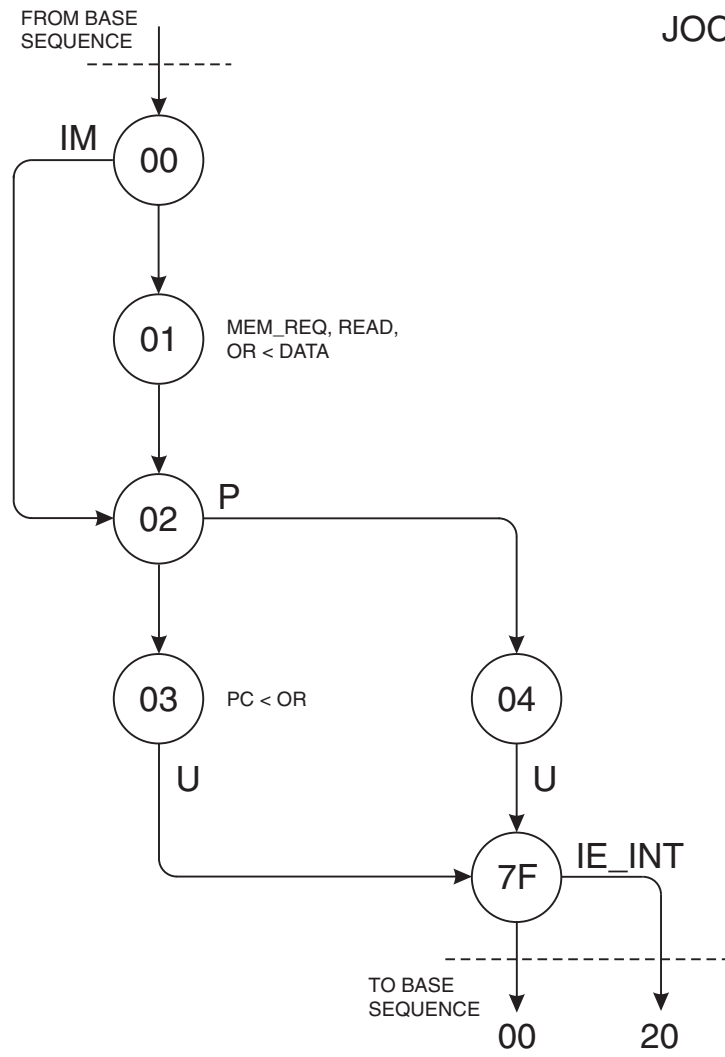

JOC (13)

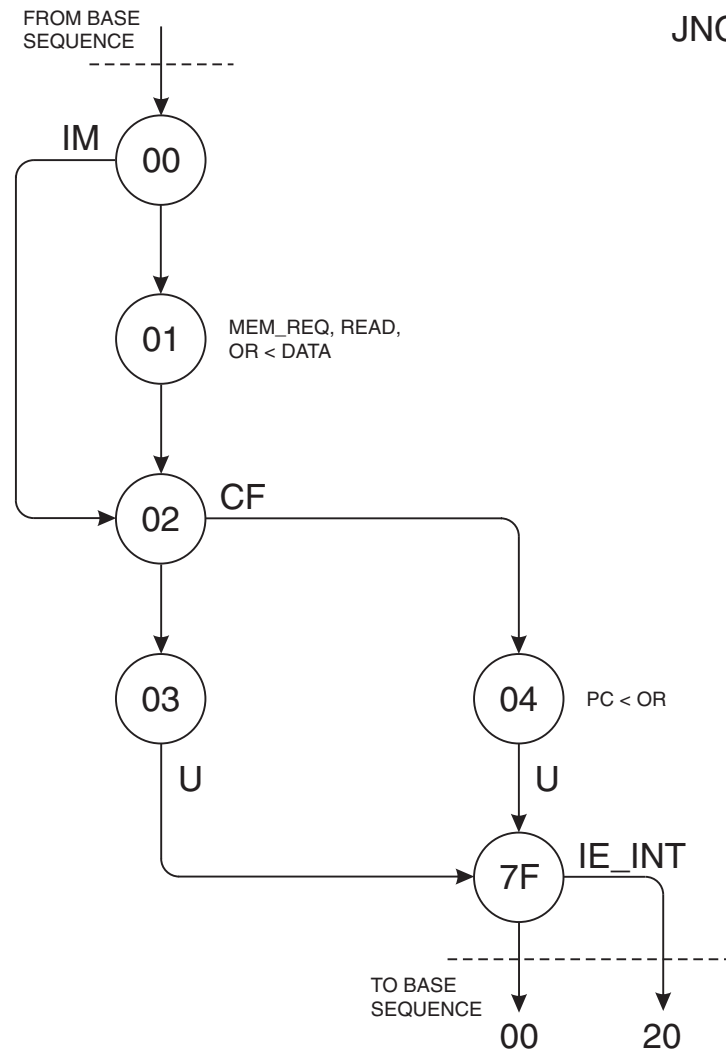

JNC (14)

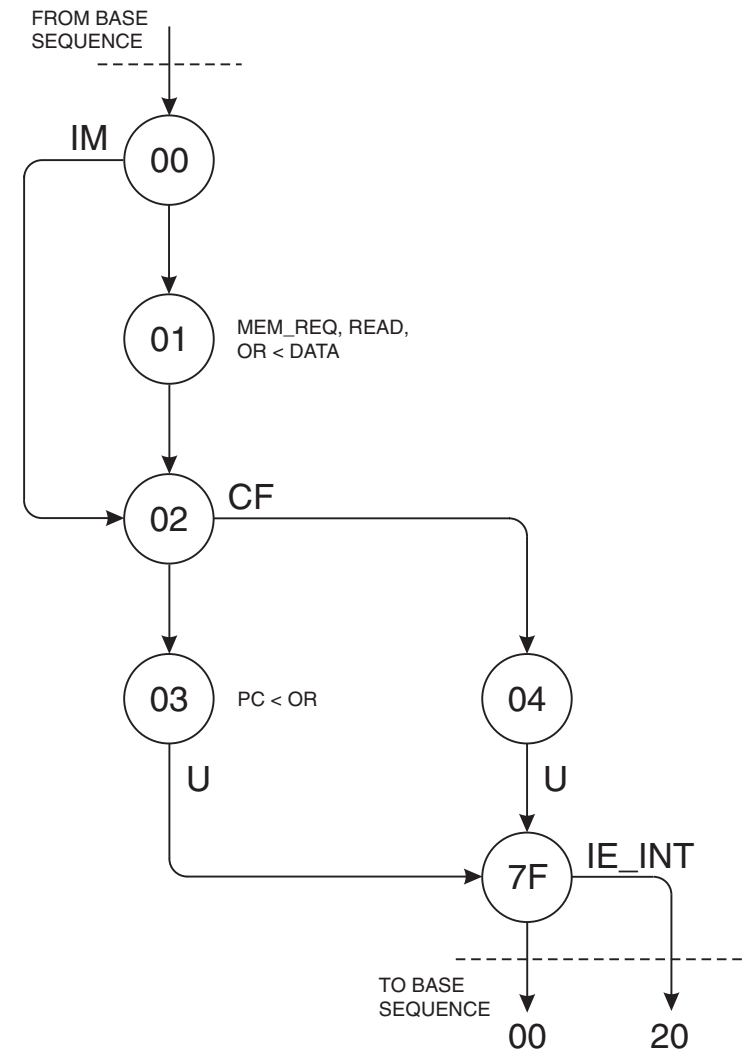

JOV (15)

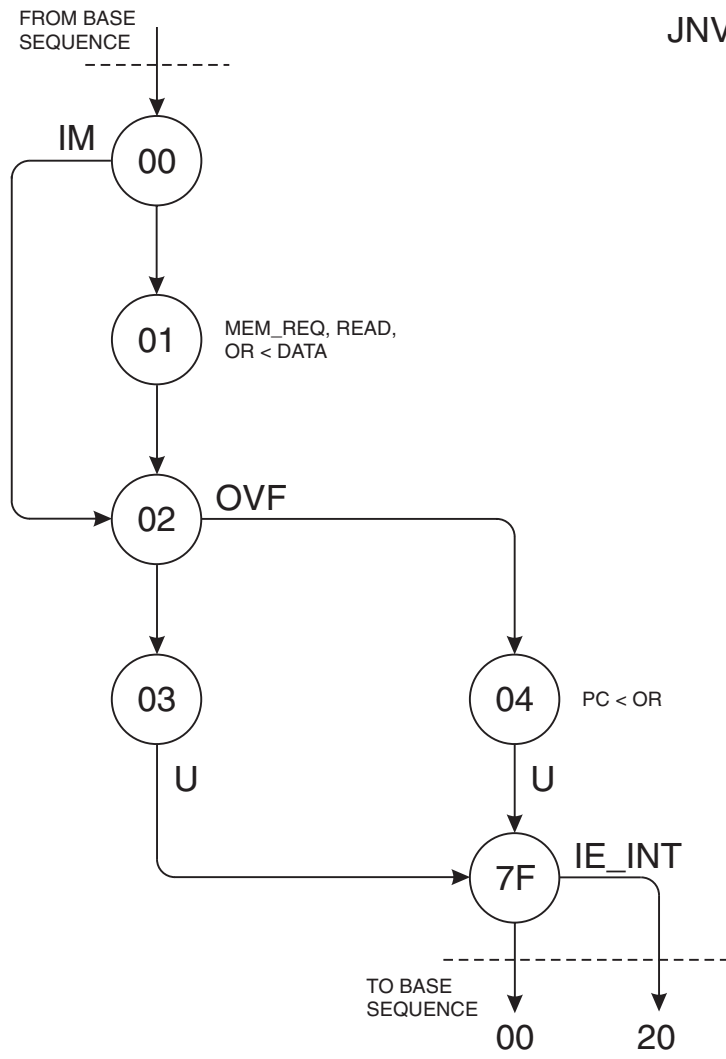

JNV(16)

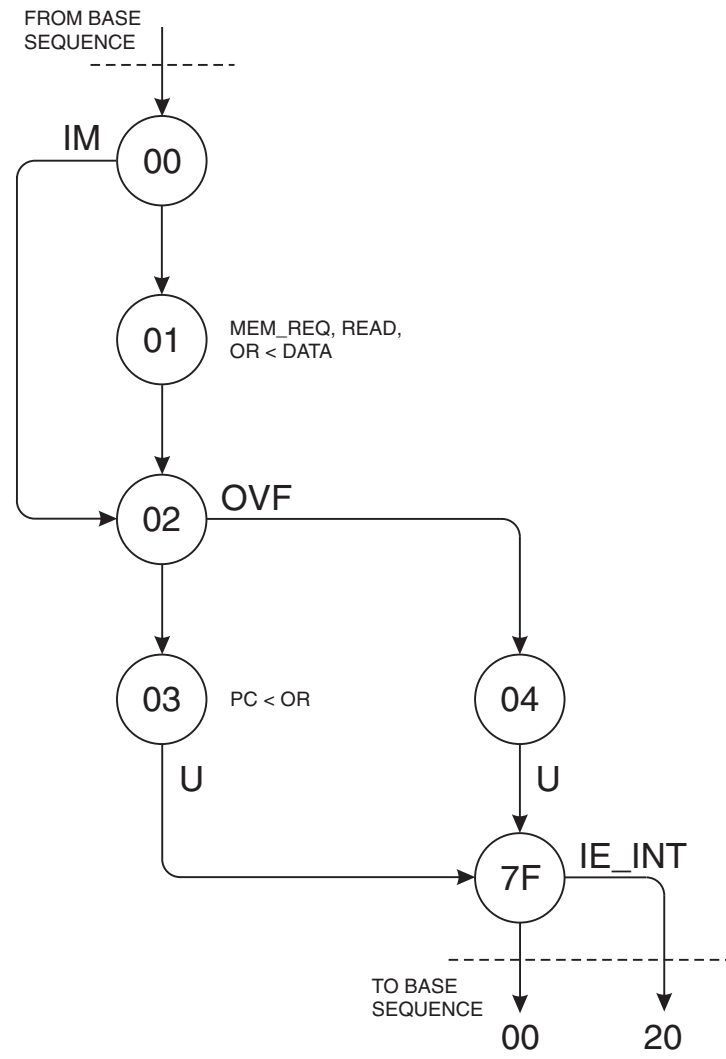

CSR (17)

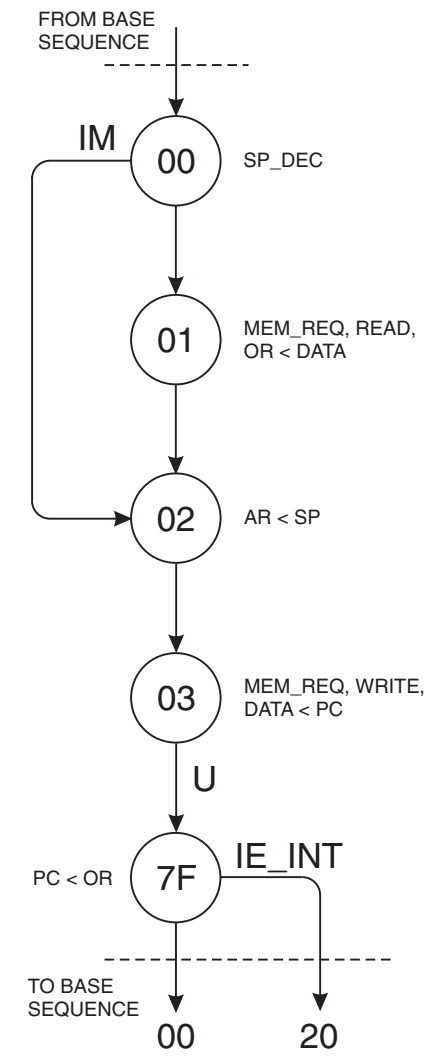

INP (18)

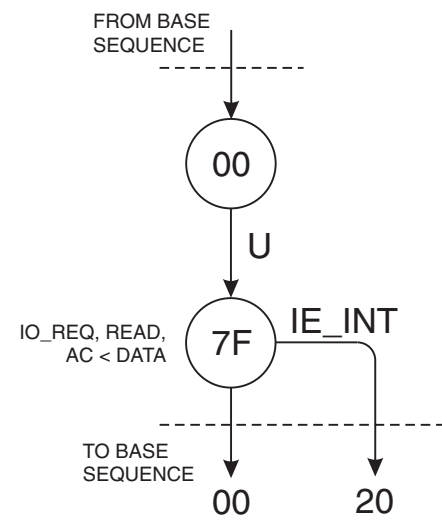

OUT (19)

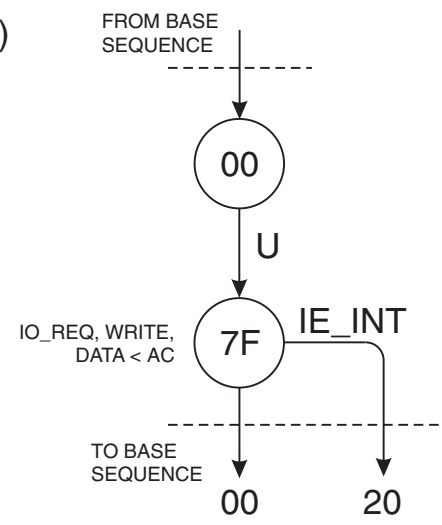

INC (1A)

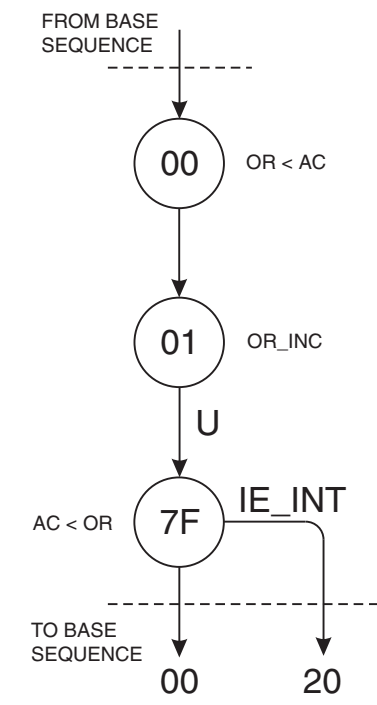

DEC (1B)

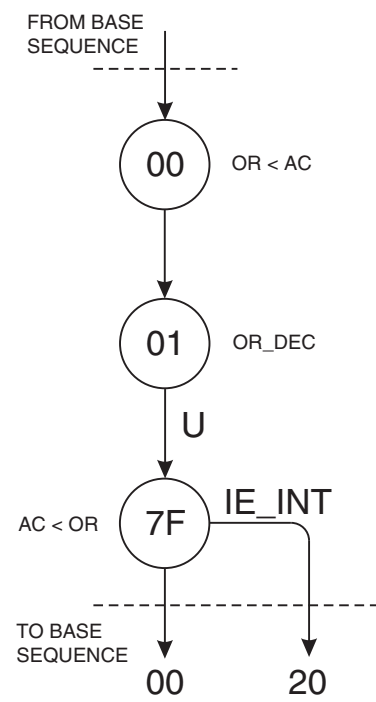

COM (1C)

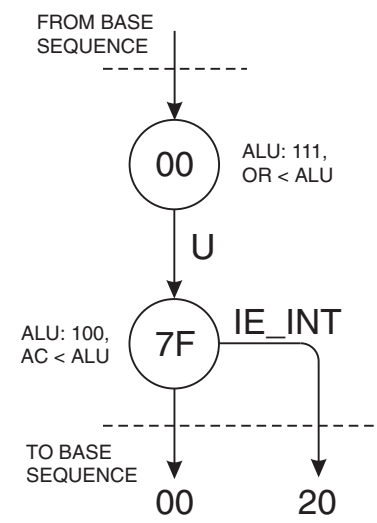

NEG (1D)

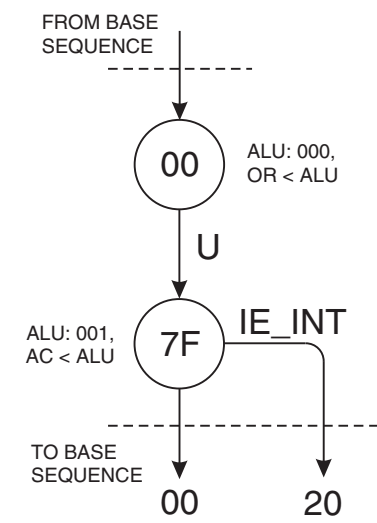

SET (1E)

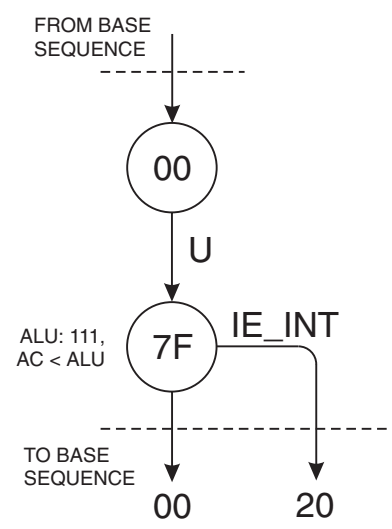

CLR (1F)

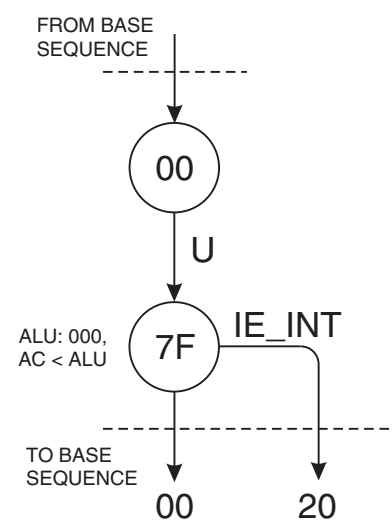

SHL (20)

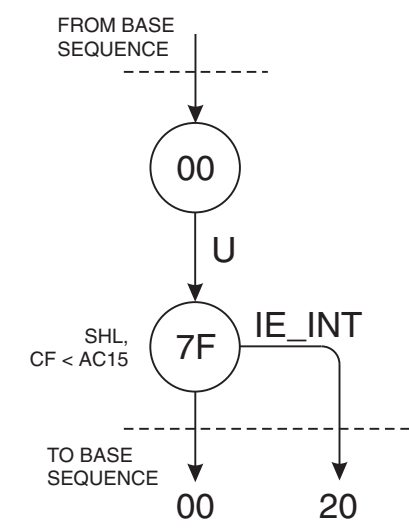

LSR (21)

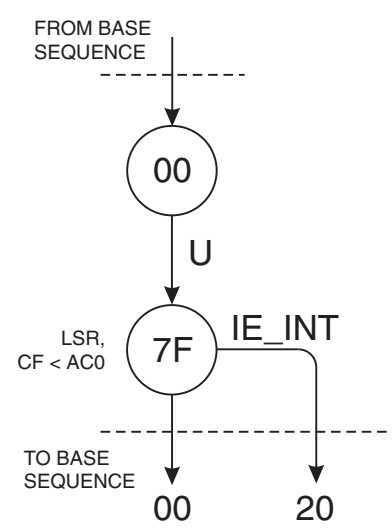

ASR (22)

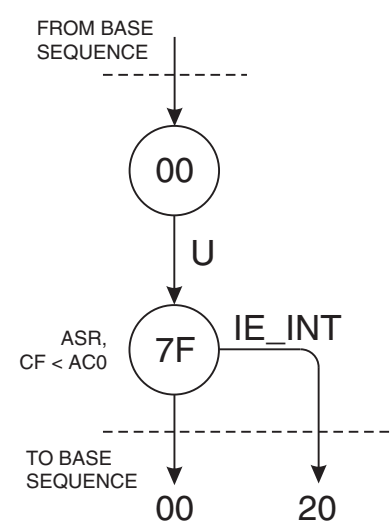

ROL (23)

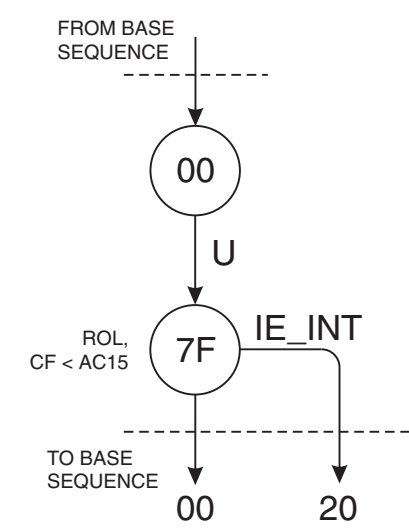

ROR (24)

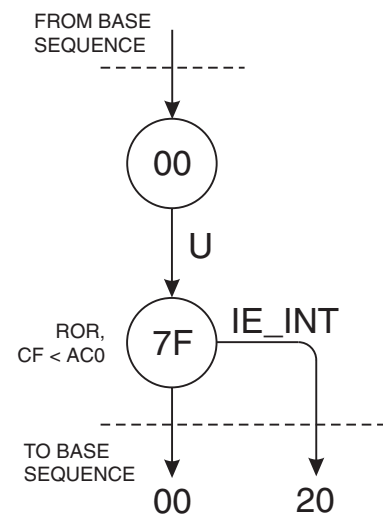

LSW (25)

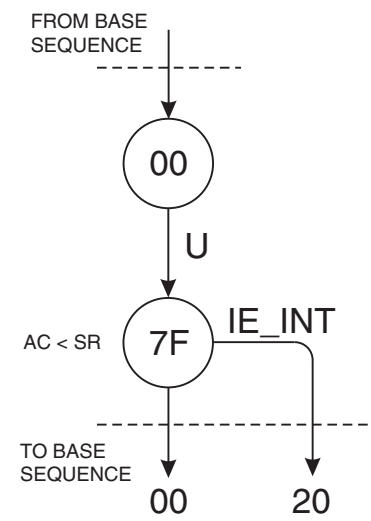

SCF (26)

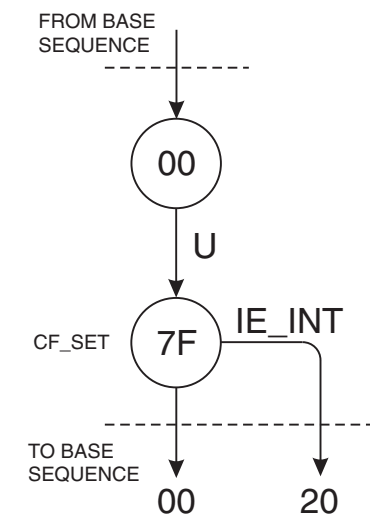

CCF (27)

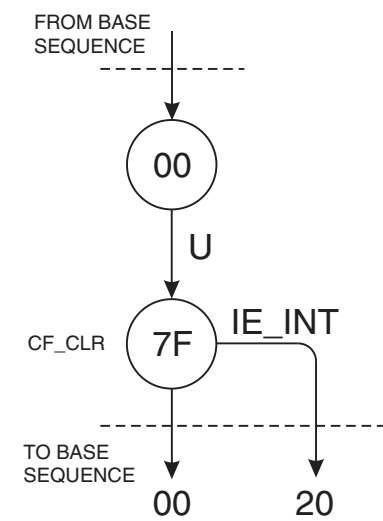

PSA (28)

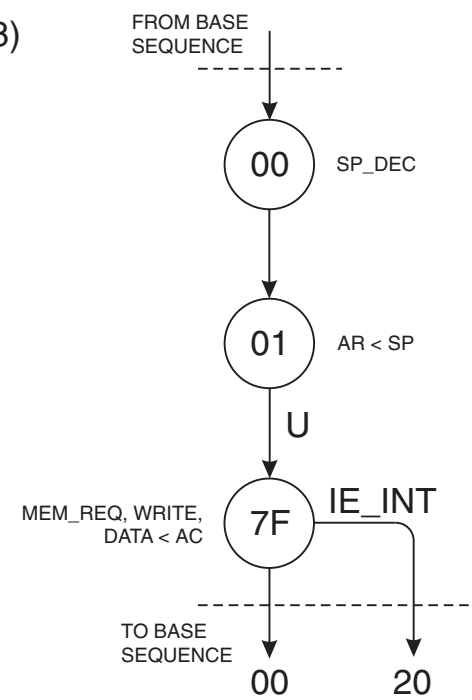

POA (29)

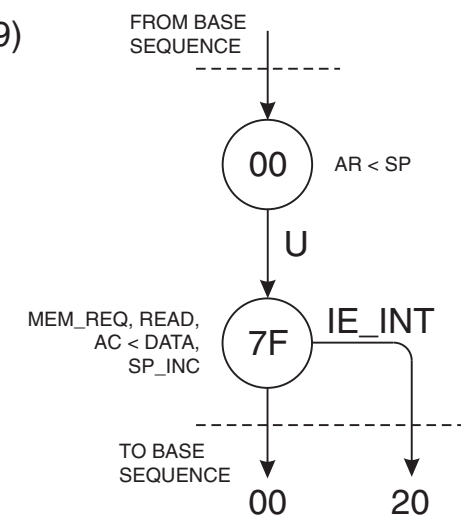

D16/M
CONTROL
SEQUENCE

INSTRUCTION
DETAILS

PSF (2A)

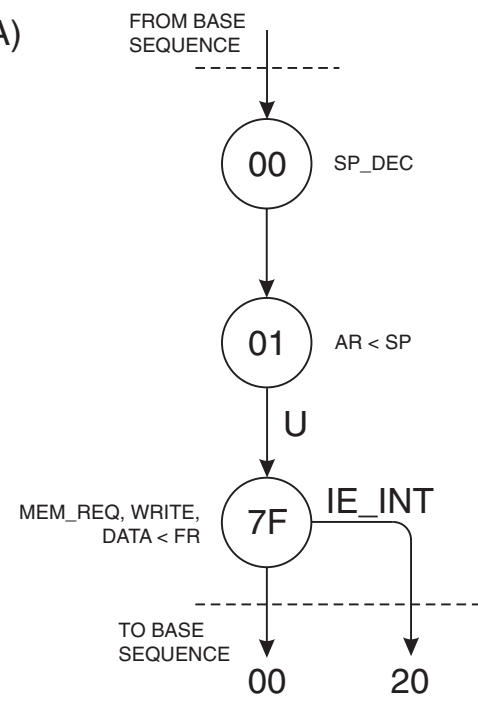

POF (2B)

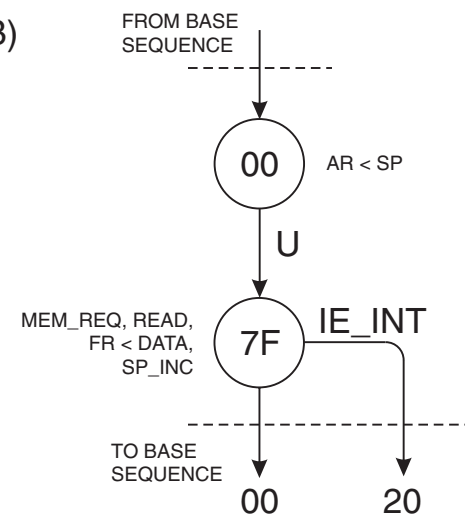

ENI (2C)

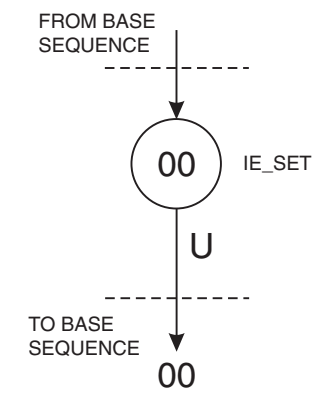

DII (2D)

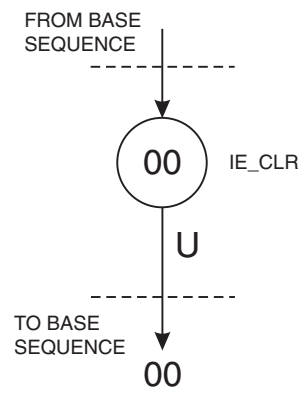

RTN (2E)

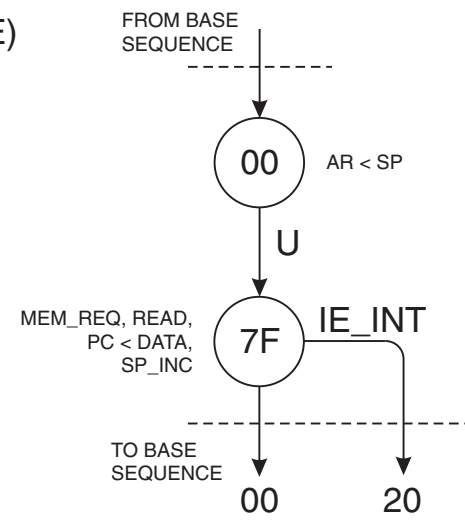

RTI (2F)

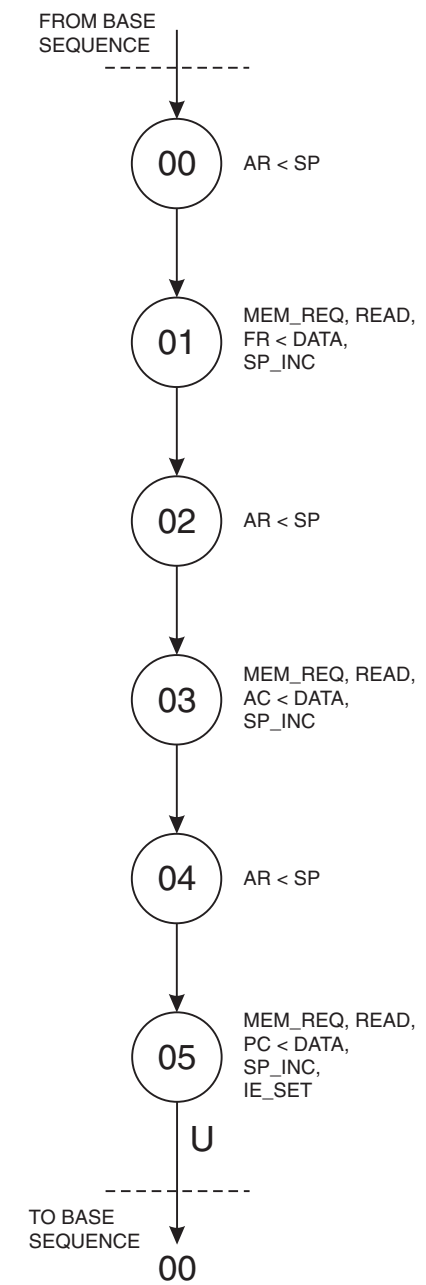

NOP (30)

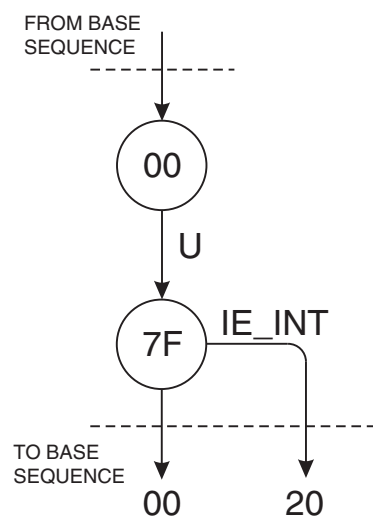

HLT (FF)

THIS INSTRUCTION SHOWN
OUT OF NUMERICAL ORDER

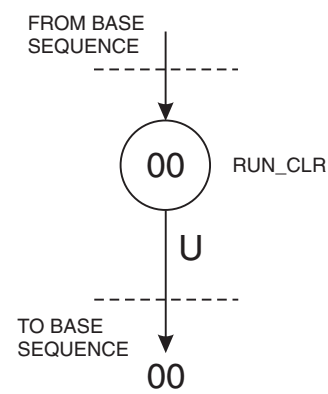

LDX (31)

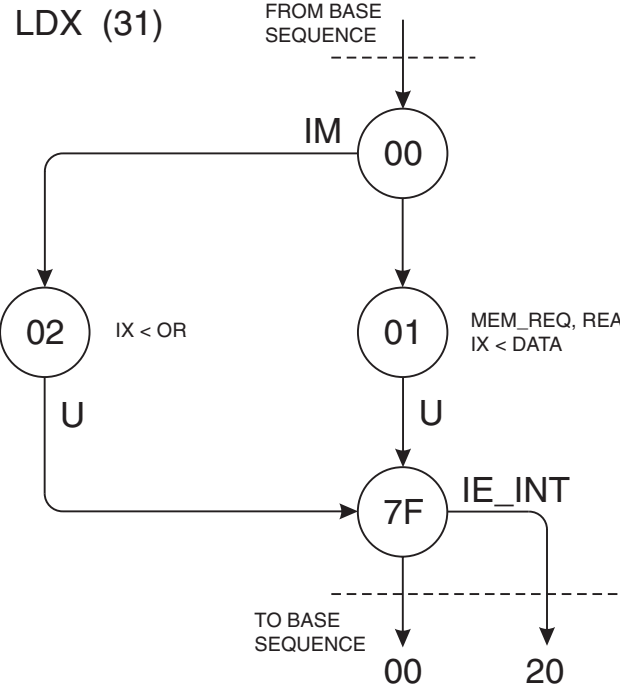

LDY (32)

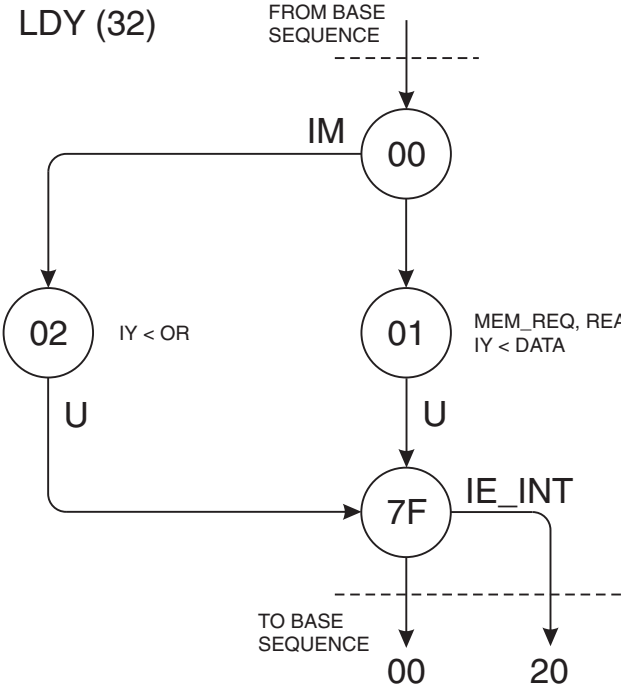

STX (33)

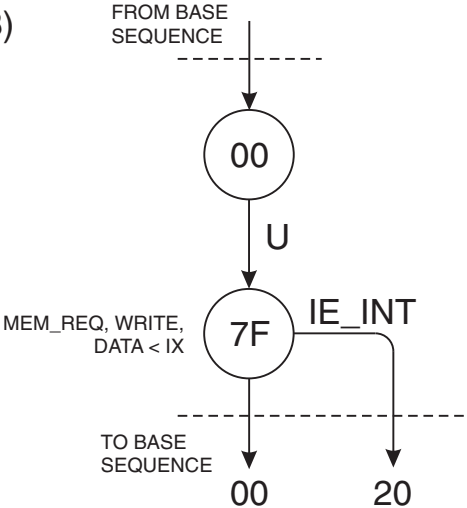

STY (34)

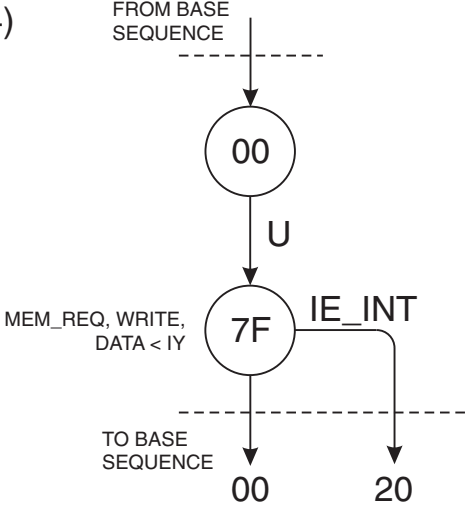

INX (35)

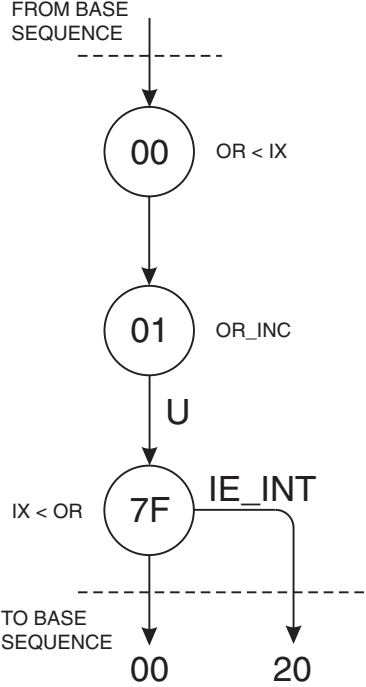

INY (36)

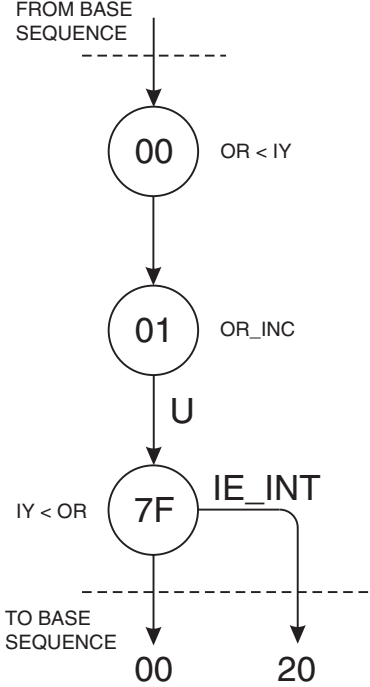

INS (37)

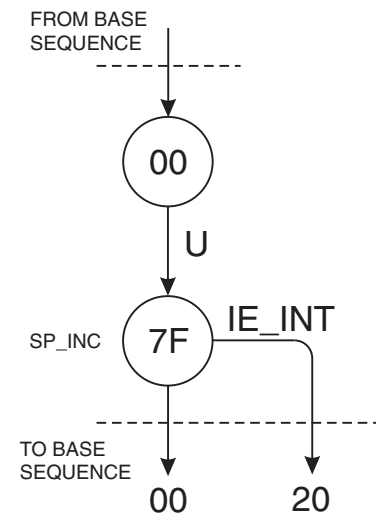

DEX (38)

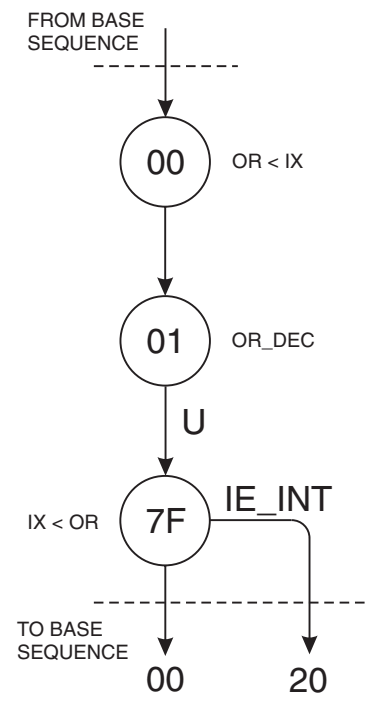

DEY (39)

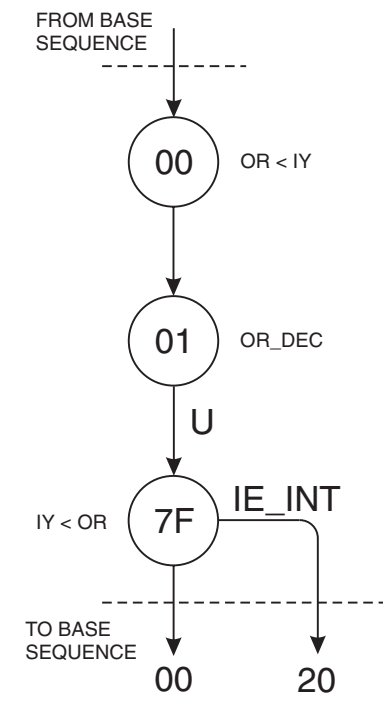

DES (3A)

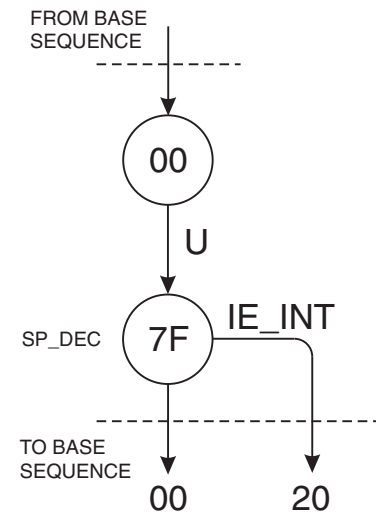

MAX (3B)

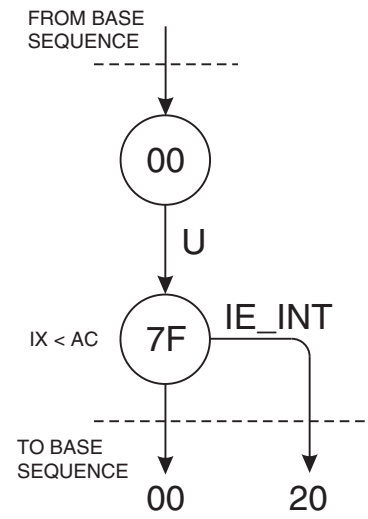

MAY (3C)

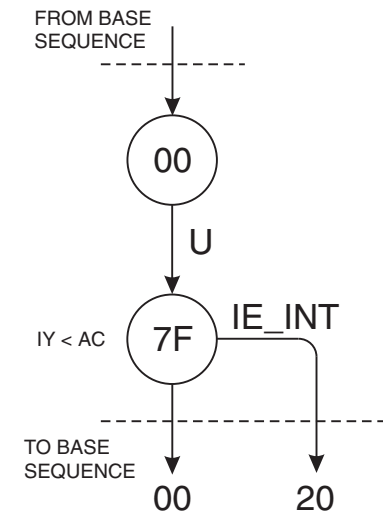

MAS (3D)

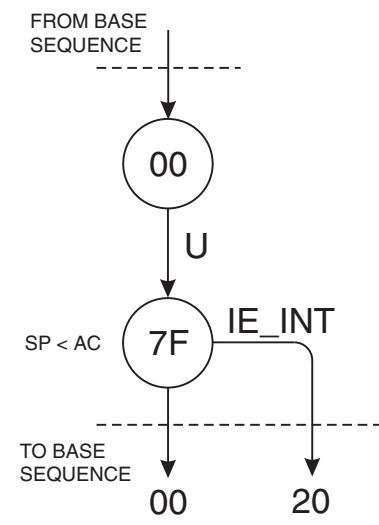

MXA (3E)

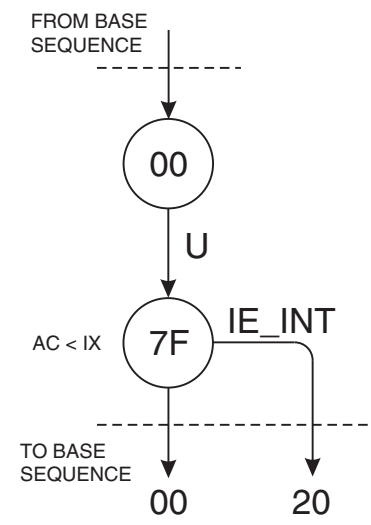

MYA (3F)

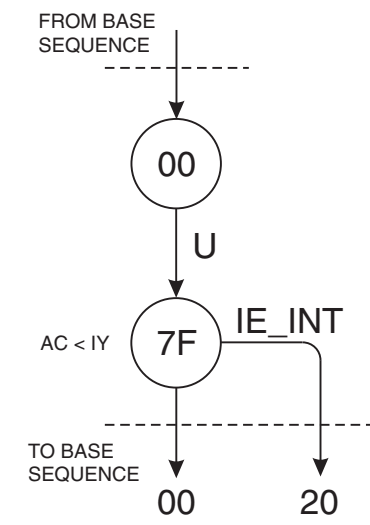

MSA (40)

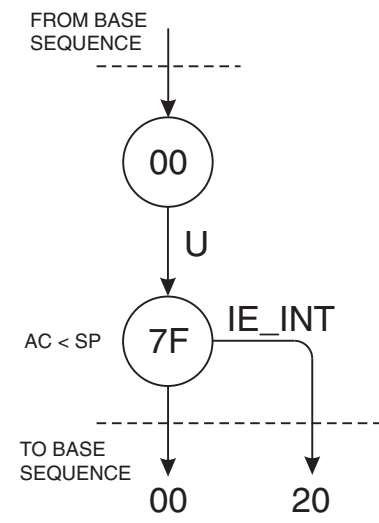

PSX (41)

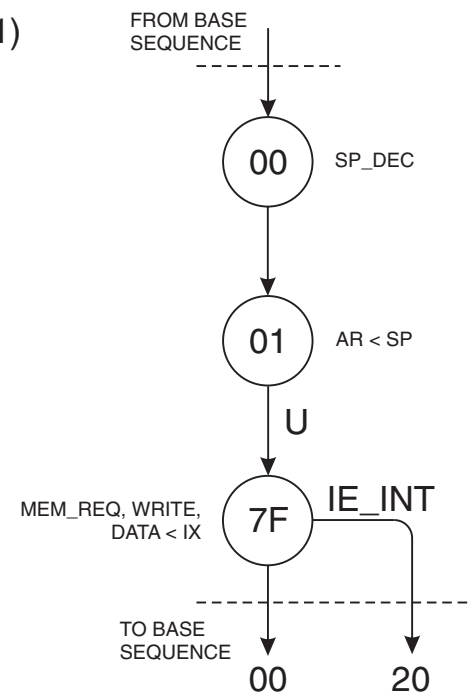

POX (42)

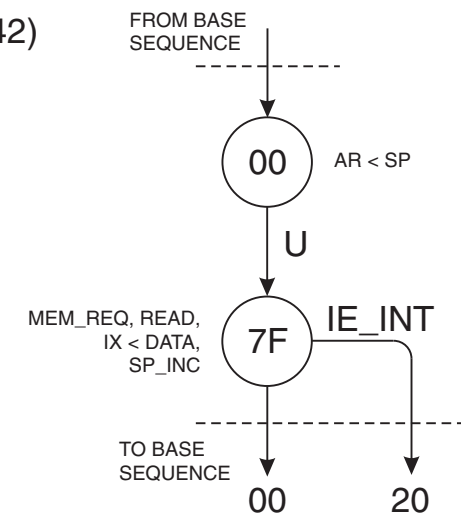

PSY (43)

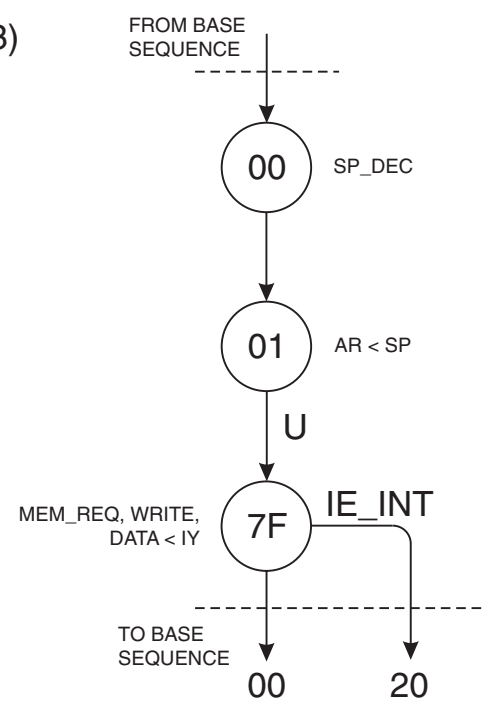

POY (44)

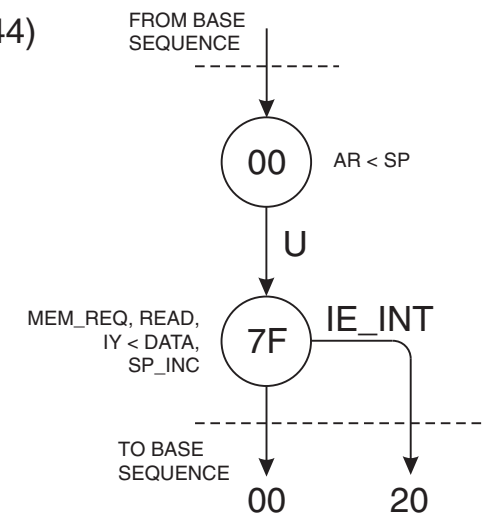

BSW (45)

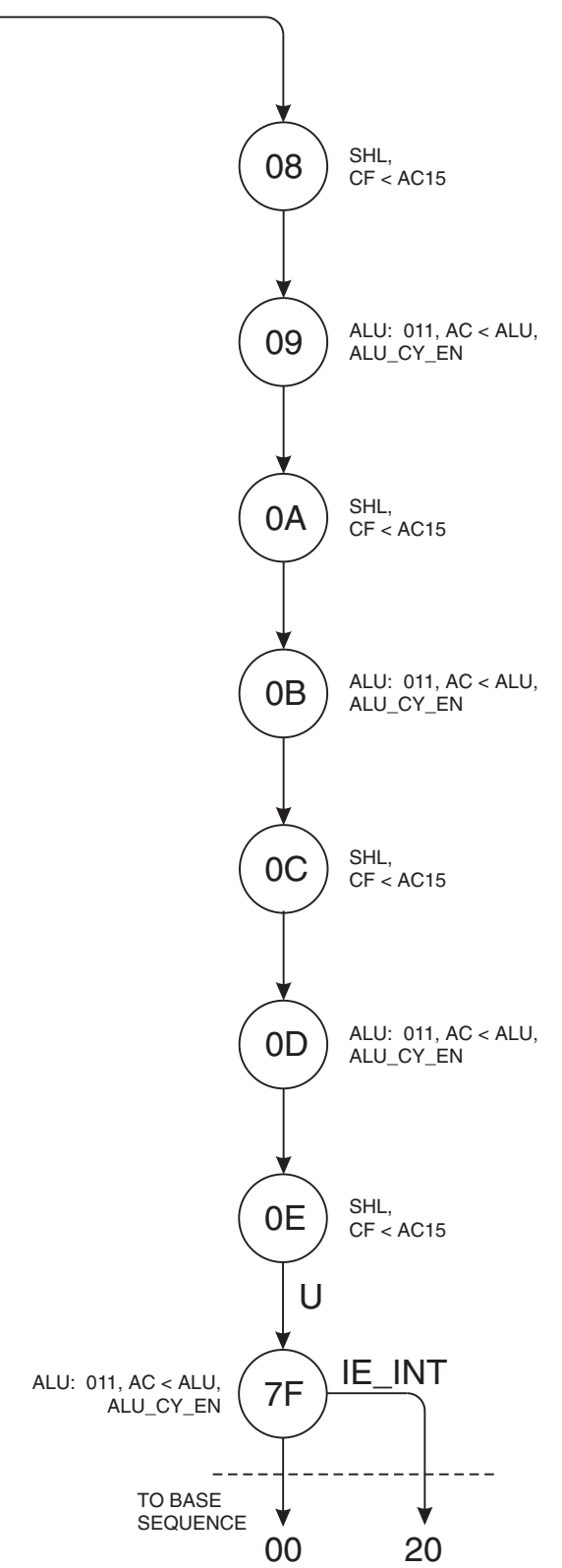
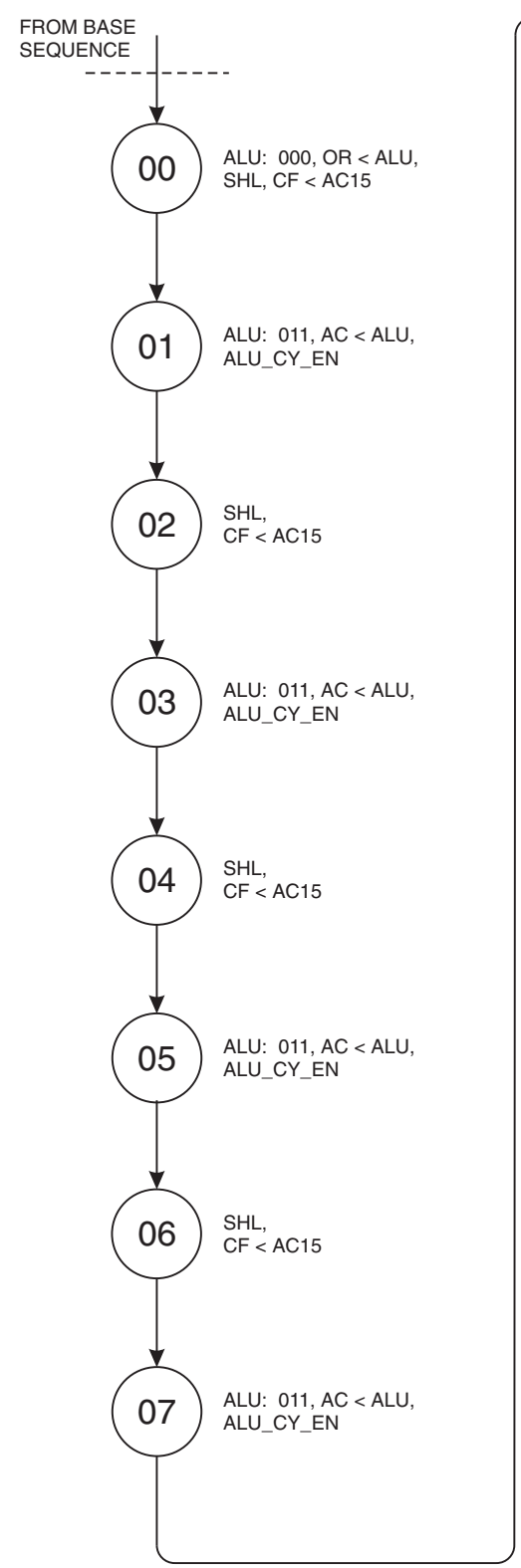

D16/M
CONTROL
SEQUENCE

INSTRUCTION
DETAILS

BSL (46)

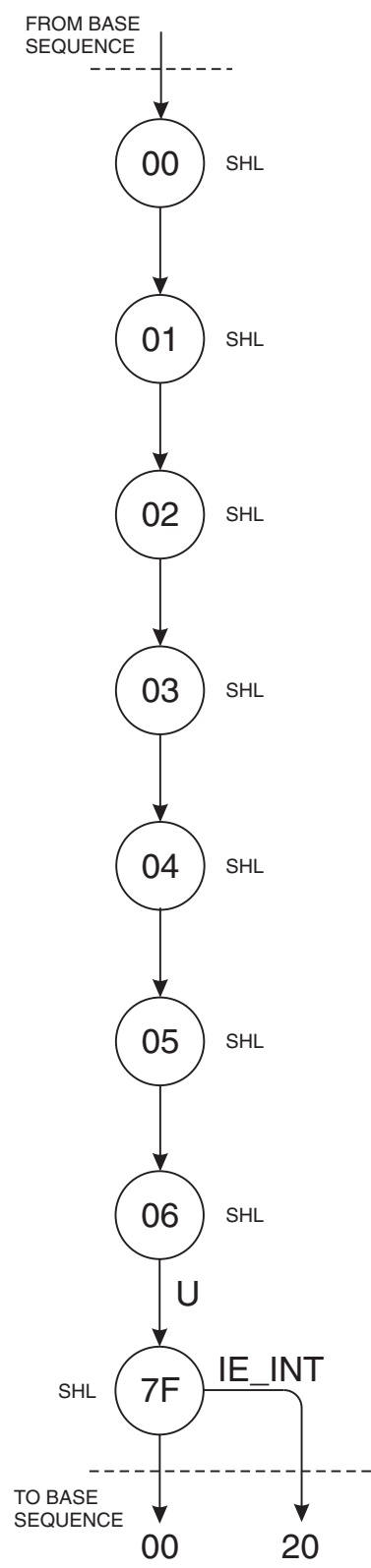

BSR (47)

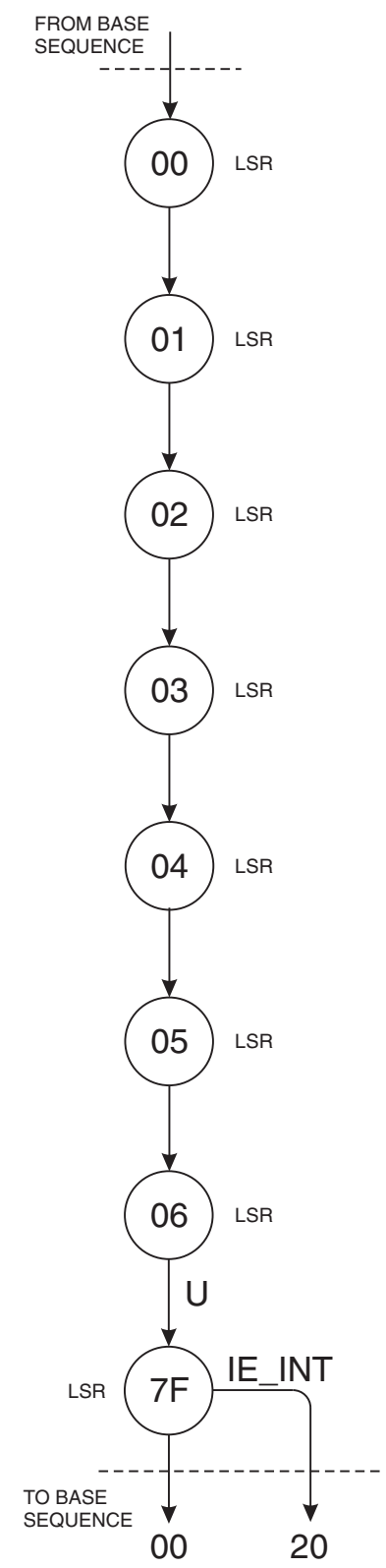

BRK (48)

